

SP2PMFWM

- I Watermark and Gas Approved
- I Investment Casting Ball, Body and Cap
- I SS316/CF8M
- I Blow-Out Proof Stem
- I Pressure Rating: 1050KPA GAS/ 1000psi WATER
- I Threaded End : BSPP female, BSPT male
- I Pressure Test: API 598
- I Lockable Handle
- I PTFE Seat
- I Temperature range: -25°C to 150°C



MATERIAL LIST

ITEM	PART	MATERIAL	QTY
1	BODY	CF8M(316)	1
2	SEAT	PTFE	2
3	BALL	SS316	1
4	BODY GASKT	PTFE	1
5	CAP	CF8M(316)	1
6	STEM	SS316	1
7	THRUST WASHER	PTFE	1
8	STEM PACKING	PTFE	1
9	HANDLE	SS304	1
10	SPRING WASHER	SS304	1
11	HANDLE NUT	SS304	1
12	GLAND NUT	SS304	1
13	HANDLE SLEEVE	PLASTIC	1

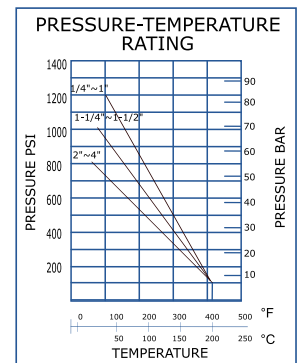
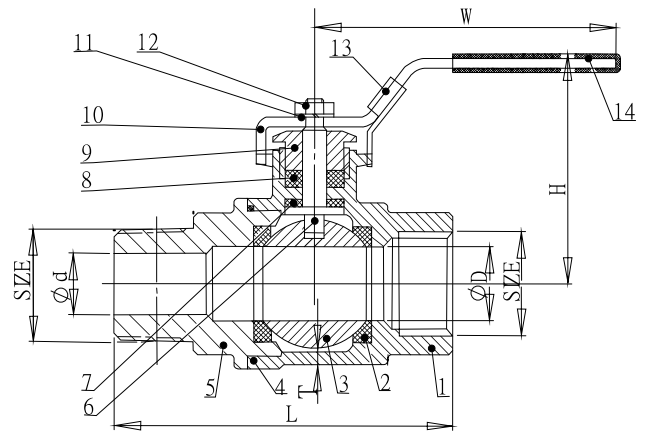

DIMENSION TABLE

SIZE	øD	DN	L	W	H	SW	WEIGHT (KG)	T
1/4"	11	8	50	105	47	19	0.17	2.75
3/8"	12.5	10	60	105	51	22	0.22	2.75
1/2"	15	15	75	118	56	26	0.3	2.25
3/4"	20	20	80	118	58.5	31	0.38	2.25
1"	25	25	90	150	74	38	0.61	2.5
1-1/4"	32	32	110	150	79	48	0.98	3
1-1/2"	40	40	120	182	92	54	1.59	3.5
2"	50	50	140	182	103	68	2.58	4

FLOW RATE

SIZE	M ³ /h	Pressure drop Pa
1/4"	1.5	125
3/8"	2.6	125
1/2"	5.9	125
3/4"	14.3	125
1"	23.8	125
1-1/4"	42	125
1-1/2"	64.1	125
2"	95.5	125

* Size 1/4 — 3/8 are non stock items, lead time applies.