



Valves and Fittings Supplies

1/4" - 4"

2-PC BALL VALVE, FULL BORE, THREADED END, 1000 WOG

SP2PNPT

- I Investment Casting Ball, Body and Cap
- I SS316/CF8M
- I Blow-Out Proof Stem
- I Pressure Rating: 1000psi
- I Threaded End : NPT
- I Pressure Test: API 598
- I Lockable Handle
- I PTFE Seat
- I Temperature range: -25°C to 150°C



MATERIAL LIST

ITEM	PART	MATERIAL	QTY
1	BODY	CF8M(316)	1
2	SEAT	PTFE	2
3	BALL	SS316	1
4	WASHER	PTFE	1
5	CAP	CF8M(316)	1
6	STEM	SS316	1
7	THRUST WASHER	PTFE	1
8	STEM PACKING	PTFE	1
9	LOCK WASHER	SS304	1
10	HANDLE	SS304	1
11	SPRING WASHER	SS304	1
12	HANDLE NUT	SS304	1
13	STOP PIN	SS304	1
14	HANDLE SLEEVE	PLASTIC	1

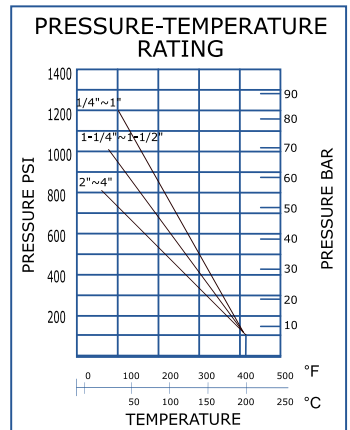
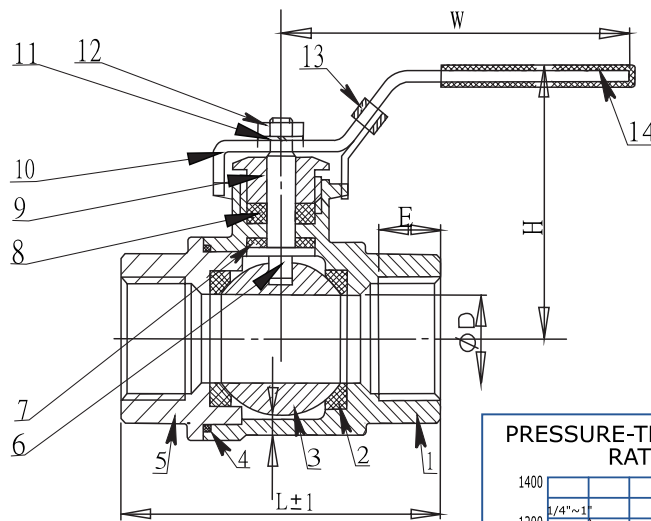

DIMENSION TABLE

SIZE	ØD	DN	L	W	E	H	WEIGHT(KG)
1/4"	11	8	50.5	84	10	52	0.195
3/8"	12.5	10	52	84	10	52	0.205
1/2"	15	15	60	105	13.5	60	0.3
3/4"	20	20	66	105	14.5	62	0.38
1"	25	25	76	160	17	75	0.61
1-1/4"	32	32	90.5	160	19	79	0.98
1-1/2"	38	40	102	192	19	92	1.59
2"	50	50	121	192	23	103	2.2
2-1/2"	65	65	157	295	26.05	127	4.44
3"	80	80	177	295	30	139	6.1
4"	100	100	210	295	32	155	11.1